

SANDERSON PIPE

2024 Product Catalog



Made with Pride in the USA | sandersonpipe.com

Servicing Your PVC Pipe Needs From Four Strategic Locations

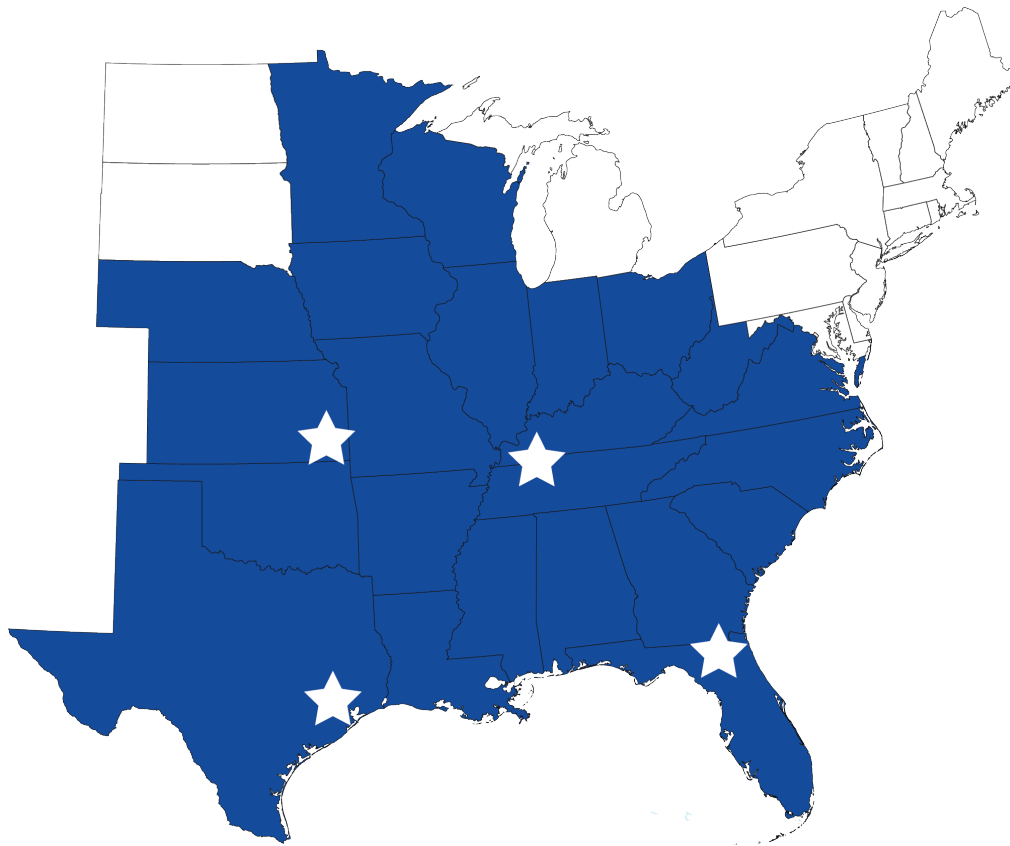

Houston, TX

(800) 966-8741

Making Quality PVC Pipe Since 1990

Pittsburg, KS

(877) 779-7473

Making Quality PVC Pipe Since 1972

Clarksville, TN

(888) 278-0393

Making Quality PVC Pipe Since 2008

Sanderson, FL

(800) 669-3553

Making Quality PVC Pipe Since 1998

*Product mix varies by plant.
Please always confirm price
and availability.*

TABLE OF CONTENTS

C900	Page 4
Sewer	Page 7
2729	Page 10
Perforated Sewer	Page 12
IPS Pressure Pipe	Page 14
SCH40/DWV	Page 18
SCH80	Page 20
Foam Core	Page 22
Well Casing	Page 24
Terms & Conditions of Sale.....	Page 26

Every effort has been made by Sanderson Pipe Corporation to offer the most current, correct and clearly expressed information possible in this publication. Nevertheless, it is possible that errors in information published may occur. Sanderson Pipe Corporation disclaims any responsibility for inadvertent errors and the accuracy of any product specifications, data or other information that may be contained in this publication. All product specifications, data and information included in this publication is subject to change without notice and provided for estimating purposes only. Please reference the Sanderson Pipe Corporation website at sandersonpipe.com for the most up to date information. (October, 2024)

AWWA C900 MANUFACTURER'S CERTIFICATION

This is to certify the pipe manufactured by Sanderson Pipe meets or exceeds the applicable engineering standards listed below for 4" through 24" C900 pipe.

Materials

Comply with ASTM D1784 for PVC 1120 cell classification 12454. Materials used in the manufacture of our certified C900 pipe are NSF/ANSI 14 and 61 listed.

Dimensions/Testing

All pipe meets or exceeds the performance requirements listed in the current version of ANSI/AWWA C900, UL1285 and FM 1612 (DR18 and DR14 12" and smaller). Each C900 pipe is hydrostatic tested to at least two times the pressure class per AWWA standards. Testing records are maintained and available upon request.

Markings on the Pipe

Identification of nominal pipe size (CI diameter), PVC, dimension ratio, ANSI/AWWA pressure class, test pressure for hydrostatic tested pipe, AWWA designation number (ANSI/AWWA C900), manufacture's name and code. Additional certified seals printed on the pipe are: NSF-pw, NSF-61, UL1285, and Factory Mutual (FM 1612 Approved for DR18 at 185 PSI and DR14 at 250 PSI only – for C900 pipe 12" and smaller).

Joints

Integral bell joint system complies with the requirements of ASTM D3139.

Gasket

All gaskets are NSF approved and comply with ASTM F477 standards.

Color

Standard C900 pressure pipe is blue. Purple (marked "Caution – Do Not Drink Reclaimed Water") and green (marked "Sewer Force Main") is available upon request. The purple and green C900 pipe will not carry the NSF-pw, NSF-61, UL1285, or Factory Mutual seals.

Length

Manufactured in 20 foot lay lengths with a 15 degree chamfer.

Tapping

It is extremely important to use the proper procedures and tools while tapping pipe. Sanderson Pipe Corporation recommends strict compliance with the requirements as specified in AWWA C605.

Installation

Sanderson Pipe Corporation recommends using installation procedures outlined in AWWA C605, Underground Installation of Polyvinyl Chloride (PVC) Pressure Pipe and Fittings for Water. The AWWA Manual M23, and Handbook of PVC Pipe Design and Construction (from Uni-Bell/PVC Pipe Association) are additional resource guides for design and installation.



Pipe Size	Outside Diameter (A)	Minimum Wall (B)		
		DR-25 (165 PSI)	DR-18 (235 PSI)	DR-14 (305 PSI)
4"	4.800"	0.192"	0.267"	0.343"
6"	6.900"	0.276"	0.383"	0.493"
8"	9.050"	0.362"	0.503"	0.646"
10"	11.100"	0.444"	0.617"	0.793"
12"	13.200"	0.528"	0.733"	0.943"
14"	15.300"	0.612"	0.850"	1.093"
16"	17.400"	0.696"	0.967"	1.243"
18"	19.500"	0.780"	1.083"	1.393"
20"	21.600"	0.864"	1.200"	1.543"
24"	25.800"	1.032"	1.433"	1.843"

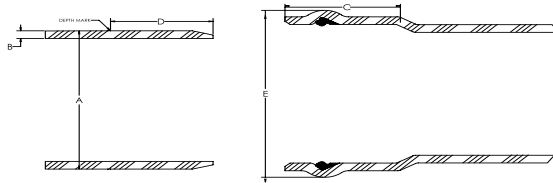

Pipe Size	Dimensions		
	*(C) Bell Length	*(D) Insertion / Reference Mark	(E) Approximate Bell OD Clearance
4"	5.50"	4.50"	6.50"
6"	6.25"	5.25"	9.25"
8"	7.50"	6.50"	11.875"
10"	8.75"	7.75"	14.500"
12"	9.25"	8.25"	16.875"
14"	10.50"	9.50"	19.500"
16"	11.00"	10.00"	22.000"
18"	11.25"	10.25"	24.500"
20"	12.00"	11.00"	27.000"
24"	13.00"	12.00"	32.000"

*May vary up to $\pm \frac{1}{2}$ "



Loading Chart | C900 Pipe

Pipe Size	Pipe Length	Pieces per Pallet	Feet per Pallet	Pallets per Truck	Feet per Truck
4"	20'	60	1,200'	12	14,400'
4" DR14	20'	50	1,000'	12	12,000'
6"	20'	28 / 7	560' / 140'	12 / 4	7,280'
6" DR14	20'	28	560'	12	6,720'
8"	20'	10	200'	20	4,000'
10"	20'	8	160'	16	2,560'
12"	20'	6 / 8	120' / 160'	6 / 6	1,960'
14"	20'	6	120'	12	1,440'
16"	20'	2 / 3	40' / 60'	10 / 10	1,000'
18"	20'	4 / 6	80' / 120'	4 / 4	800'
20"	20'	4	80'	8	640'
24"	20'	3	60'	6	360'

ASTM D3034 / ASTM F679 SEWER PIPE MANUFACTURER'S CERTIFICATION

This is to certify the pipe manufactured by Sandersons Pipe meets or exceeds the applicable engineering standards listed below for 4" through 24" Sewer Series pipe.

Materials

Comply with ASTM D1784 for cell classification 12454.

Additional labeling on the SDR 26 and PS 115 sewer series includes the words: "Heavy Wall Sewer Pipe".

Dimensions/Testing

All pipe sizes 4" through 15" meets or exceeds the performance requirements listed in the current version of ASTM D3034.

Joints

Integral bell joint system conform to ASTM D3212.

18" through 24" pipe meets or exceeds the performance requirements listed in the current version of ASTM F679.

Gaskets

All gaskets used in the manufacturing of the pipe comply with ASTM F477 standards.

Markings on the Pipe

4" through 15": Identification of nominal pipe size, cell classification, SDR class, ASTM designation D3034, material code, manufacturer's name and code.

Color

Gasketed sewer pipe is green. Solvent weld sewer pipe is available in green or white.

18" through 24": Identification of nominal pipe size, cell classification, pipe stiffness designation (PS series), ASTM designation F679, material code, manufacturer's name and code.

Length

Gasketed sewer pipe is manufactured in 14' lay lengths. Solvent weld sewer pipe is available in 10' or 20' over-all length.



ASTM D3034 Gasketed Sewer Pipe

Pipe Size	Outside Diameter (A)	Minimum Wall (B)		*Bell Length (C)	*Insertion/ Reference Mark (D)	Approximate Bell OD Clearance (E)
		SDR35	SDR26			
4"	4.215"	0.120"	0.162"	4.00"	3.50"	5.250"
6"	6.275"	0.180"	0.241"	5.00"	4.25"	7.500"
8"	8.400"	0.240"	0.323"	5.50"	5.00"	9.875"
10"	10.500"	0.300"	0.404"	6.50"	6.00"	12.375"
12"	12.500"	0.360"	0.481"	7.00"	6.50"	14.625"
15"	15.300"	0.437"	0.588"	7.50"	6.50"	18.000"

*May vary up to $\pm \frac{1}{2}$ "

ASTM F679 Gasketed Sewer Pipe

Pipe Size	Outside Diameter (A)	Minimum Wall (B)		*Bell Length (C)	*Insertion/ Reference Mark (D)	Approximate Bell OD Clearance (E)
		PS46	PS115			
18"	18.701"	0.499"	0.671"	9.00"	8.00"	21.750"
21"	22.047"	0.588"	0.791"	10.25"	9.25"	24.750"
24"	24.803"	0.661"	0.889"	11.00"	10.00"	27.750"

*May vary up to $\pm \frac{1}{2}$ "

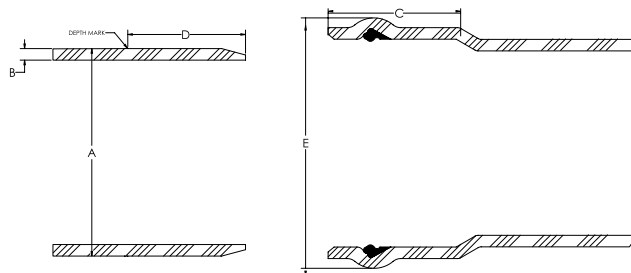

ASTM 3034 Solvent Weld Sewer Pipe

Pipe Size	Outside Diameter	Minimum Wall SDR35	*Bell Length	Approximate Bell OD Clearance
3"	3.250"	0.093"	3"	3.485"
4"	4.215"	0.120"	4"	4.500"
6"	6.275"	0.180"	5"	6.750"

*May vary up to $\pm \frac{1}{2}$ "



Loading Chart | Sewer

Gasketed

Pipe Size	Pipe Length	Pieces per Pallet	Feet per Pallet	Pallets per Truck	Feet per Truck
4"	14'	53	742'	30	22,260'
6"	14'	26	364'	24	8,736'
8"	14'	17	238'	24	5,712'
10"	14'	12	168'	18	3,024'
12"	14'	4 / 8	56' / 112'	6 / 18	2,352'
15"	14'	6	84'	18	1,512'
18"	14'	2	28'	30	840'
21"	14'	4	56'	12	672'
24"	14'	4	56'	12	672'

Solvent Weld

Pipe Size	Pipe Length	Pieces per Pallet	Feet per Pallet	Pallets per Truck	Feet per Truck
3"	10'	84	840'	40	33,600'
4"	10'	53	530'	40	21,200'
	20'	53	1,060'	20	21,200'
6"	10'	26	260'	32	8,320'
	20'	26	520'	16	8,320'

ASTM D2729 SEWER PIPE MANUFACTURER'S CERTIFICATION

This is to certify the pipe manufactured by Sanderson Pipe Corporation meets or exceeds the applicable engineering standards listed under ASTM D2729.

Materials

Comply with ASTM D1784 for cell classification 12454.

Dimensions/Testing

All pipe meets or exceeds the performance requirements listed in the current version of ASTM D2729.

Markings on the Pipe

Identification of nominal pipe size, PVC Sewer Pipe, ASTM designation D2729, material code, manufacturer's name and code.

Color

ASTM D2729 pipe is white.

Length

Standard pipe is manufactured in 10' over-all lengths.

Pipe Size	Outside Diameter	Minimum Wall	*Bell Length
3"	3.250"	0.070"	3"
4"	4.215"	0.075"	4"
6"	6.275"	0.100"	5"

*May vary up to $\pm \frac{1}{2}$ "



Loading Chart | ASTM D2729

Pipe Size	Pipe Length	Pieces per Pallet	Feet per Pallet	Pallets per Truck	Feet per Truck
3"	10'	84	840'	40	33,600'
4"	10'	53	530'	40	21,200'
6"	10'	26	260'	32	8,320'

PERFORATED ASTM D3034 / ASTM D2729 SEWER PIPE MANUFACTURER'S CERTIFICATION

This is to certify the pipe manufactured by Sanderson Pipe Corporation meets or exceeds the applicable engineering standards listed under ASTM D3034 or ASTM D2729.

Materials

Comply with ASTM D1784 for cell classification 12454.

size, PVC Sewer Pipe or PVC Perforated Pipe, ASTM designation D2729, material code, manufacturer's name and code.

Dimensions/Testing

All pipe meets or exceeds the performance requirements listed in the current version of ASTM D3034 or ASTM D2729.

Color

ASTM D3034 perforated pipe is green.
ASTM D2729 perforated pipe is white.

Markings on the Pipe

ASTM D3034: Identification of nominal pipe size, cell classification, ASTM designation D3034, material code, manufacturer's name and code.

ASTM D2729: Identification of nominal pipe

Length

Standard pipe is manufactured in 10' over-all lengths.

Typical 2-Row Pattern for Perforated Pipe

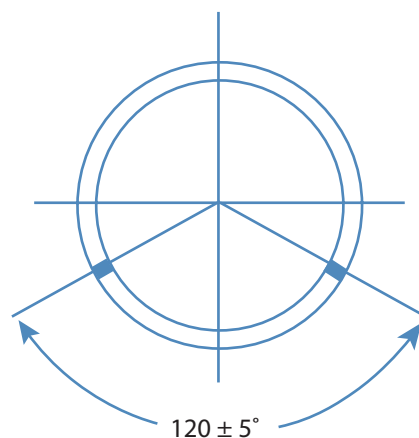

ASTM D3034					
Pipe Size	Outside Diameter	Minimum Wall	*Bell Length	Hole Size	Hole Spacing per Row
3"	3.250"	0.093"	3"	½"	6"
4"	4.215"	0.120"	4"	½"	6"
6"	6.275"	0.180"	5"	½"	6"

*May vary up to ± ½"

ASTM D2729					
Pipe Size	Outside Diameter	Minimum Wall	*Bell Length	Hole Size	Hole Spacing per Row
3"	3.250"	0.070"	3"	½"	6"
4"	4.215"	0.075"	4"	½"	6"
6"	6.275"	0.100"	5"	½"	6"

*May vary up to ± ½"

Loading Chart | ASTM D3034

Pipe Size	Pipe Length	Pieces per Pallet	Feet per Pallet	Pallets per Truck	Feet per Truck
3"	10'	84	840'	40	33,600'
4"	10'	53	530'	40	21,200'
6"	10'	26	260'	32	8,320'

Loading Chart | ASTM D2729

Pipe Size	Pipe Length	Pieces per Pallet	Feet per Pallet	Pallets per Truck	Feet per Truck
3"	10'	84	840'	40	33,600'
4"	10'	53	530'	40	21,200'
6"	10'	26	260'	32	8,320'

ASTM D2241 IPS PRESSURE PIPE MANUFACTURER'S CERTIFICATION

This is to certify the pipe manufactured by Sanderson Pipe meets or exceeds the applicable engineering standards listed below for ½" through 12" IPS pressure pipe.

Materials

Comply with ASTM D1784 for PVC 1120 cell classification 12454. Materials used in the manufacture of certified SDR series pipe are NSF/ANSI 14 and 61 listed.

Dimensions/Testing

All pipe meets or exceeds the performance requirements listed in the current version of ASTM D2241.

Markings on the Pipe

Identification of nominal pipe size, plastic pipe material code, SDR class, pressure rating, ASTM designation D2241, manufacturer's name, code, and the National Sanitation Foundation seal for potable water (NSF-pw).

Joints

Integral bell joint system conform to ASTM D3139.

Gaskets

All gaskets used in the manufacturing of the pipe are NSF approved and comply with ASTM F477 standards.

Color

Standard IPS pressure pipe is white. Blue is available upon request. Purple (marked "Caution - Do Not Drink Reclaimed Water") and green (marked "Sewer Force Main") are also available upon request. The purple and green IPS pressure pipe will not carry the NSF-pw seal.

Length

Solvent weld products are produced in 20' over-all lengths. Gasketed products are produced in 20' and 44' lay lengths with a 15 degree chamfer. 44' pipe is manufactured in Kansas only.



Gasketed

Pipe Size	Outside Diameter (A)	Minimum Wall (B)					*Bell Length (C)	*Insertion / Reference Mark (D)	Approximate Bell OD Clearance (E)
		SDR 41 (PC 100)	SDR 32.5 (PC 125)	SDR 26 (PC 160)	SDR 21 (PC 200)	SDR 17 (PC 250)			
2"	2.375"	N/A	N/A	0.091"	0.113"	0.140"	4.75"	3.75"	3.250"
2 ½"	2.875"	N/A	N/A	0.110"	0.137"	N/A	5.25"	4.25"	4.375"
3"	3.500"	N/A	N/A <td 0.135"	0.167"	0.206"	5.25"	4.50"	4.750"	
4"	4.500"	N/A	N/A	0.173"	0.214"	0.265"	5.50"	4.50"	5.850"
6"	6.625"	0.162"	0.204"	0.255"	0.316"	0.390"	6.50"	5.00"	8.500"
8"	8.625"	0.210"	0.265"	0.332"	0.410"	0.508"	7.25"	6.00"	10.750"
10"	10.750"	0.262"	0.331"	0.413"	0.511"	0.632"	8.25"	7.00"	12.875"
12"	12.750"	0.311"	0.392"	0.490"	0.606"	0.750"	9.50"	8.00"	15.875"

*May vary up to $\pm \frac{1}{2}$ "

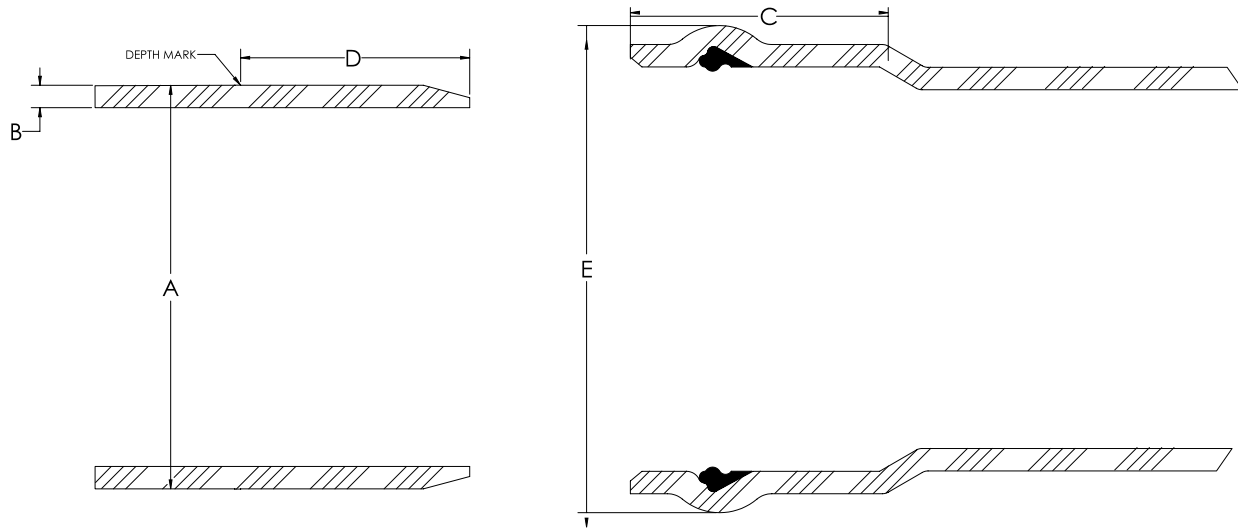

Solvent Weld

Pipe Size	Outside Diameter	Minimum Wall					*Bell Length
		SDR 41 (PC 100)	SDR 32.5 (PC 125)	SDR 26 (PC 160)	SDR 21 (PC 200)	SDR 13.5 (PC 315)	
½"	0.840"	N/A	N/A	N/A	N/A	0.062"	1.75"
¾"	1.050"	N/A	N/A	N/A	0.060"	N/A	2.00"
1"	1.315"	N/A	N/A	N/A	0.063"	N/A	2.00"
1 ¼"	1.660"	N/A	N/A	0.064"	0.079"	N/A	2.25"
1 ½"	1.900"	N/A	N/A	0.073"	0.090"	N/A	2.75"
2"	2.375"	N/A	N/A	0.091"	0.113"	N/A	4.50"
2 ½"	2.875"	N/A	0.088"	0.110"	0.137"	N/A	4.75"
3"	3.500"	0.085"	0.108"	0.135"	0.167"	N/A	4.75"
4"	4.500"	0.110"	0.138"	0.173"	0.214"	N/A	6.25"
5"	5.563"	0.136"	0.171"	N/A	N/A	N/A	6.75"
6"	6.625"	0.162"	0.204"	0.255"	N/A	N/A	6.75"
8"	8.625"	0.210"	0.265"	N/A	N/A	N/A	7.00"
10"	10.750"	0.262"	0.331"	N/A	N/A	N/A	8.00"
12"	12.750"	0.311"	0.392"	N/A	N/A	N/A	9.00"

*May vary up to ± ½"

Loading Chart | IPS Pressure Pipe

Pipe Size	Pipe Length	Pieces per Pallet	Feet per Pallet	Pallets per Truck	Feet per Truck
½"	20'	450	9,000'	48	432,000'
¾"	20'	440	8,800'	32	281,600'
1"	20'	280	5,600'	32	179,200'
1 ¼"	20'	165	3,300'	36	118,800'
1 ½"	20'	221	4,420'	24	106,080'
2"	20'	140	2,800'	20	56,000'
	44'	140	6,160'	10	61,600'
2 ½"	20'	131	2,620'	16	41,920'
3"	20'	63	1,260'	24	30,240'
	44'	63	2,772'	12	33,264'
4"	20'	57	1,140'	16	18,240'
	44'	57	2,508'	8	20,064'
5"	20'	24	480'	24	11,520'
6"	20'	26	520'	16	8,320'
	44'	26	1,144'	8	9,152'
8"	20'	14	280'	16	4,480'
	44'	14	616'	8	4,928'
8" SDR41/32.5	20'	20	400'	12	4,800'
10"	20'	12	240'	12	2,880'
	44'	8	352'	8	2,816'
12"	20'	8/4	160'/80'	12/4	2,240'
	44'	4/3	176'/132'	7/7	2,156'

SCHEDULE 40 PRESSURE AND DWV PIPE MANUFACTURER’S CERTIFICATION

This is to certify the pipe manufactured by Sanderson Pipe Corporation meets or exceeds the applicable engineering standards listed under ASTM D1785 Potable Water (PW) and/or D2665 Drain, Waste, Vent (DWV) for Solvent Weld and Plain End.

Materials

Comply with ASTM D1784 for PVC 1120 cell classification 12454. Materials used in the manufacture of certified SCH40/DWV pipe are NSF/ANSI 14 and 61 listed.

Dimensions/Testing

All pipe meets or exceeds the performance requirements listed in the current version of ASTM D1785/D2665. All Schedule 40 pipe is dual marked ASTM D1785/D2665 with the

exception of the ½”, ¾”, 1” and 2 ½” pipe sizes and purple pipe.

Markings on the Pipe

Identification of nominal pipe size, plastic pipe material code, schedule size, pressure rating, ASTM designation D1785 and/or D2665, manufacturer’s name and code. One or both of the following certified seals will be identified on the pipe: National Sanitation Foundation seal for potable water (NSF-pw) and/or National Sanitation Foundation for drain, waste, vent (NSF-dwv).

Color

Standard Schedule 40/DWV is white. Purple (marked “Caution – Do Not Drink Reclaimed Water”) is also available upon request. The purple Schedule 40 pipe will not carry the NSF-pw seal or the ASTM D2665 mark.

Length

Standard pipe is manufactured in 20’ over-all lengths. ½” through 8” is available in 10’ over-all lengths.

4” and above bell end pipe are furnished with 15 degree chamfers.

Pipe Size	Pressure Rating	Outside Diameter	Minimum Wall	*Bell Length
½”	600	0.840”	0.109”	1.75”
¾”	480	1.050”	0.113”	2.00”
1”	450	1.315”	0.133”	2.00”
1 ¼”	370	1.660”	0.140”	2.25”
1 ½”	330	1.900”	0.145”	2.75”
2”	280	2.375”	0.154”	4.00”
2 ½”	300	2.875”	0.203”	4.50”
3”	260	3.500”	0.216”	4.50”
4”	220	4.500”	0.237”	6.50”
6”	180	6.625”	0.280”	7.00”
8”	160	8.625”	0.322”	7.00”
10”	140	10.750”	0.365”	8.00”
12”	130	12.750”	0.406”	9.00”
14”	130	14.000”	0.437”	9.00”
16”	130	16.000”	0.500”	10.00”
18”	130	18.000”	0.562”	12.00”

*May vary up to ± ½”



Loading Chart | SCH40/DWV

Pipe Size	Pipe Length	Pieces per Pallet	Feet per Pallets	Pallets per Truck	Feet per Truck
½"	10'	450	4,500'	60	270,000'
	20'	450	9,000'	30	270,000'
¾"	10'	440	4,400'	44	193,600'
	20'	440	8,800'	22	193,600'
1"	10'	280	2,800'	48	134,400'
	20'	280	5,600'	24	134,400'
1 ¼"	10'	165	1,650'	60	99,000'
	20'	165	3,300'	30	99,000'
1 ½"	10'	221	2,210'	40	88,400'
	20'	221	4,420'	20	88,400'
2"	10'	140	1,400'	40	56,000'
	20'	140	2,800'	20	56,000'
2 ½"	20'	131	2,620'	16	41,920'
3"	10'	63	630'	48	30,240'
	20'	63	1,260'	24	30,240'
4"	10'	57	570'	32	18,240'
	20'	57	1,140'	16	18,240'
6"	10'	26	260'	32	8,320'
	20'	26	520'	16	8,320'
8"	10'	14	140'	32	4,480'
	20'	14	280'	16	4,480'
10"	20'	12	240'	12	2,880'
12"	20'	8	160'	12	1,920'
14"	20'	6	120'	12	1,440'
16"	20'	6	120'	12	1,440'
18"	20'	2	40'	20	800'

SCHEDULE 80 PRESSURE PIPE MANUFACTURER'S CERTIFICATION

This is to certify the pipe manufactured by Sanderson Pipe Corporation meets or exceeds the applicable engineering standards listed under ASTM D1785 Potable Water (PW) for Plain End.

Materials

Comply with ASTM D1784 for PVC 1120 cell classification 12454. Materials used in the manufacture of certified SCH80 pipe are NSF/ANSI 14 and 61 listed.

Dimensions/Testing

All pipe meets or exceeds the performance requirements listed in the current version of ASTM D1785.

Markings on the Pipe

Identification of nominal pipe size, plastic pipe material code, schedule size, pressure rating, ASTM designation D1785, manufacturer's name and code. The following certified seal will

be identified on the pipe: National Sanitation Foundation seal for potable water (NSF-pw).

Color

Schedule 80 pipe is grey.

Length

Standard pipe is manufactured in 20' over-all lengths (only offered in plain end).

Pipe Size	Pressure Class	Outside Diameter	Minimum Wall
½"	850	.840"	0.147"
¾"	690	1.050"	0.154"
1"	630	1.315"	0.179"
1 ¼"	520	1.660"	0.191"
1 ½"	470	1.900"	0.200"
2"	400	2.375"	0.218"
3"	370	3.500"	0.300"
4"	320	4.500"	0.337"
6"	280	6.625"	0.432"
8"	250	8.625"	0.500"



Loading Chart | SCH80

Pipe Size	Pipe Length	Pieces per Pallet	Feet per Pallet	Pallets per Truck	Feet per Truck
½"	20'	450	9,000'	30	270,000'
*¾"	20'	440	8,800'	22	193,600'
*1"	20'	280	5,600'	24	134,400'
*1 ¼"	20'	165	3,300'	30	99,000'
1 ½"	20'	221	4,420'	20	88,400'
*2"	20'	140	2,800'	20	56,000'
3"	20'	63	1,260'	24	30,240'
*4"	20'	57	1,140'	16	18,240'
6"	20'	26	520'	16	8,320'
8"	20'	14	280'	16	4,480'

*Actual truck load quantities are limited by weight.

ASTM F891 SCH 40 FOAM CORE MANUFACTURER’S CERTIFICATION

This is to certify the pipe manufactured by Sanderson Pipe Corporation meets or exceeds the applicable engineering standards listed below for ASTM F891 Schedule 40 coextruded cellular core drain, waste, vent pipe.

Materials

Comply with ASTM D4396 cell classification 11432.

code, the National Sanitation Foundation seal for drain, waste, vent (NSF-dwv). Additional labeling on the pipe will include “NOT FOR PRESSURE”.

Dimensions/Testing

All pipe meets or exceeds the performance requirements listed in the current version of ASTM F891.

Color

Foam Core pipe is white.

Markings on the Pipe

Identification of nominal pipe size, plastic pipe material code, schedule size, ASTM designation F891, the labeling “COEXTRUDED CELLULAR CORE PVC PIPE”, manufacturer’s name and

Length

Manufactured in 10’ or 20’ over-all lengths (only offered in plain end).

Assembly

Refer to standard ASTM D2855.

Pipe Size	Outside Diameter	Minimum Wall
1 ½”	1.900”	0.145”
2”	2.375”	0.154”
3”	3.500”	0.216”
4”	4.500”	0.237”
6”	6.625”	0.280”



Loading Chart | Foam Core

Pipe Size	Pipe Length	Pieces per Pallet	Feet per Pallet	Pallets per Truck	Feet per Truck
1 ½"	10'	221	2,210'	48	106,080'
	20'	221	4,420'	24	106,080'
2"	10'	140	1,400'	40	56,000'
	20'	140	2,800'	20	56,000'
3"	10'	63	630'	48	30,240'
	20'	63	1,260'	24	30,240'
4"	10'	57	570'	32	18,240'
	20'	57	1,140'	16	18,240'
6"	10'	26	260'	32	8,320'
	20'	26	520'	16	8,320'

ASTM F480 WELL CASING MANUFACTURER’S CERTIFICATION

This is to certify the pipe manufactured by Sanderson Pipe Corporation meets or exceeds the applicable engineering standards listed under ASTM F480 in conjunction with SCH 40 or SDR 21 Well Casing.

Materials

Comply with ASTM D1784 for PVC 1120, cell classification 12454. Materials used in the manufacture of the pipe are NSF/ANSI 14 and 61 certified.

Dimensions/Testing

All pipe meets or exceeds the performance requirements listed in the current version of ASTM F480, ASTM D1785 and D2241.

Markings on the Pipe

Identification of nominal pipe size, plastic pipe material code, schedule or SDR series, pressure rating, ASTM designation F480, manufacturer’s name, code, National Sanitation Foundation

seal for potable water (NSF- pw), (NSF-wc), the labeling “Well Casing IC-O” followed by the impact classification, and either the labeling of ASTM D1785 or D2241 on the pipe.

Color

Well casing is white.

Length

Manufactured in 20’ lay lengths.

Pipe Size	Outside Diameter	Minimum Wall		*Bell Length
		SCH40	SDR21	
2"	2.375"	0.154"	N/A	5"
3"	3.500"	0.216"	N/A	5"
4"	4.500"	0.237"	0.214"	6"
6"	6.625"	0.280"	N/A	7"

*May vary up to ± ½"



Loading Chart | Well Casing

Pipe Size	Pipe Length	Pieces per Pallet	Feet per Pallet	Pallets per Truck	Feet per Truck
2"	20'	140	2,800'	20	56,000'
3"	20'	63	1,260'	24	30,240'
4"	20'	57	1,140'	16	18,240'
6"	20'	26	520'	16	8,320'

1. **ACCEPTANCE:** All orders, modifications, or cancellations received by Sanderson Pipe Corporation (SPC) shall be in writing (facsimile acceptable), and shall not be deemed accepted by SPC unless such confirmation is in writing (facsimile acceptable). SPC reserves the right to accept or reject any order. Possession of a price list does not constitute an offer to sell. Unless otherwise specified, quotations shall be for specified items at specified prices and shall be deemed to be an offer to sell the entire volume of pipe subject to the quotation. Partial acceptance by SPC's customers shall be deemed to be a counteroffer. All quotations shall be valid for a period of 48 hours from time of transmission unless otherwise specified in writing.
2. **PRICES:** Prices, discounts, and terms are subject to change without notice. All orders are accepted subject to prices and discounts in effect at time of shipment or pickup.
3. **TERMS OF PAYMENT:** Any payments not made when due shall bear interest from the due date until paid at 1.5% per month or the maximum rate allowed by law.
4. **ORDERS:** No invoice will be issued in a net amount of less than \$250.00. All orders will be priced on size of pickup or shipment.
5. **RETURNS:** All returns must be approved in advance by SPC. Any returned goods will be accepted after written approval of SPC only. Returns must be prepaid and a handling charge of 20% will be made as well as the original outgoing freight charge - if shipment is prepaid. Returned material must be in marketable condition as determined by SPC to receive credit.
6. **ERRORS AND CLAIMS:** SPC will correct any errors on its part, but cannot assume responsibility for the errors of others. Claims for shipping errors must be made within ten (10) days from receipt of order. Claims for shortages or damages resulting from handling of the shipment must be made direct to the carrier. Be sure to have the carrier note and sign such shortage or damage on freight bill for your use in filing claim against carrier.
7. **SPECIAL OR NON-STANDARD ORDERS:** Special or non-standard orders will be subject to advance payment or deposits. Such orders are non-cancelable and non-returnable once manufactured so long as the product is manufactured to the agreed upon specifications.
8. **FREIGHT ALLOWANCE:** All shipments are F.O.B. Factory.
 - a. Freight prepaid and allowed subject to acceptance by SPC on orders for single shipments to single destinations for truck load quantities.
 - b. When customer requests routing or carrier (Truck or Rail) higher than the most economical way, only the lowest commercial carrier rate will be allowed.
 - c. Shipments will be made only to standard Common Carrier destinations and delivery points unless specific pricing is arranged for shipment to job sites or other uncommon locations. Buyer will be notified of non-acceptance of any order that entails higher freight costs or packaging costs.
9. **CANCELED OR MODIFIED ORDERS:** All orders are entered immediately for processing; changes will be subject to approval by the Sales Department. SPC reserves the right to consider any addition to an existing order as a separate and new order, subject to the terms and conditions as outlined herein. Cancellation of any order after acceptance by SPC may result in a penalty charge, based upon the status of the order at the time of cancellation.
10. **BACK ORDERS:** Back orders will not be written if the amount is less than \$250.00. If a customer requests items to be back-ordered, then such back orders will be priced as provided under Orders.
11. **TITLE AND RISK OF LOSS:** Notwithstanding any portion of the freight charges that may be paid by SPC, title and risk of loss pass from SPC to Buyer when SPC places the pipe in the custody of the Common Carrier.
12. **TAXES, ETC.:** Any tax, tariff, or other governmental charge upon the production, sale, and/or shipment of the pipe sold hereunder now or herein after imposed by federal, state, municipal, or other governmental authorities, shall be added to the price of the pipe and shall be paid by Buyer.

13. **FORCE MAJEURE:** SPC shall not be liable for any delay or failure by it to make any shipments if such delay or failure is caused by any event beyond its reasonable control, including without limitation, act of God, war, riot, fire, explosion, mechanical breakdown, terrorism, strikes or labor trouble, plant shutdown, unavailability of or interference with necessary transportation, any raw material or power shortage, or compliance with any law, regulation, or other requirement of any governmental authority.
14. **IMPAIRMENT OF CREDIT:** If, in SPC's judgment, Buyer's credit shall become impaired at any time, SPC shall forthwith have the right to decline to make any shipments except for cash until such time as said credit has been re-established to SPC's satisfaction.
15. **WARRANTY:** Sanderson Pipe Corporation (SPC) plastic pipe is warranted to be manufactured in accordance with THE APPLICABLE SPECIFICATIONS AND MATERIALS and to be free from defects in material and workmanship using our specification as a standard. This warranty, and claims under this warranty, shall be deemed waived unless received in writing by SPC within thirty (30) days from the date the defect was discovered, or should have been discovered. NO OTHER WARRANTY, EXPRESS OR IMPLIED, INCLUDING ANY WARRANTY OF MERCHANTABILITY OR FITNESS FOR A PARTICULAR PURPOSE IS GIVEN. Sanderson Pipe Corporation does hereby warrant its PVC Pipe to be free from defects in material and workmanship under normal use and service for a period of twelve (12) months from the date of invoice.
16. **ARBITRATION:** To the maximum extent not prohibited by law, any controversy, dispute, or claim arising out of, in connection with or relating to the transaction provided for herein, including but not limited to any claim based on or arising from an alleged tort or an alleged breach of any agreement shall, at the request of SPC or the customer (either before or after the commencement of judicial proceedings), be settled by arbitration pursuant to Title 9 of the United States Code, which the parties hereto acknowledge and agree applies to the transaction involved herein, and in accordance with the Commercial Arbitration Rules of the American Arbitration Association (the "AAA"). If Title 9 of the United States Code is inapplicable to any such claim, dispute, or controversy for any reason, such arbitration shall be conducted pursuant to the Florida General Arbitration Act and in accordance with the Commercial Arbitration Rules of the AAA. In any such arbitration proceeding: (i) all statutes of limitations, which would otherwise be applicable, shall apply; and (ii) the proceeding shall be conducted in Jacksonville, Florida, by a single arbitrator. The arbitrator shall be selected by process of appointment from a panel pursuant to Section 13 AAA Commercial Arbitration Rules and shall be either an active attorney or retired judge with an AAA acknowledged expertise in the subject matter of the controversy, dispute or claim. Any award rendered in any such arbitration proceeding shall be final and binding, and judgment upon any such award may be entered in any court having jurisdiction.
17. **LIMITATION ON ACTIONS:** Any claim made by Buyer on account of damage, discrepancies in quantity, or patent and obvious defects in the pipe, must be made in writing within twenty (20) days after arrival of the pipe at its destination. Any action for breach of this agreement, other than for nonpayment, must be commenced within one year after the date of the particular shipment upon which such claim is based. SPC's liability for damages shall not exceed the purchase price of the particular shipment with respect to which damages are claimed and shall not include any special, incidental, indirect, punitive or consequential damages, which are hereby expressly waived.
18. **GOVERNING LAW:** Any dispute between SPC and Buyer shall be determined in accordance with the laws of the State of Florida. Venue with respect to any such dispute shall lie in Baker County, Florida.
19. **INCONSISTENT TERMS:** These general terms and conditions, together with any sales confirmation pertaining to a particular shipment, shall constitute the entire agreement of SPC and Buyer with respect to the purchase of the pipe, and shall supersede all prior or contemporaneous understandings, oral or written, between the parties with respect to the same. No provisions of these general terms and conditions shall be affected by any purchase order, acknowledgement, shipping document, or other document received from Buyer containing terms and conditions inconsistent with or in addition to those set forth herein, unless SPC specifically agrees in writing to the inconsistent or additional terms.
20. **LEGAL FEES:** SPC shall be entitled to reimbursement of reasonable attorney's or collection fees if it becomes necessary to engage the services of an attorney or other organization to collect any sums owed SPC hereunder.

SANDERSON PIPE

Houston, TX
(800) 966-8741

Pittsburg, KS
(877) 779-7473

Clarksville, TN
(888) 278-0393

Sanderson, FL
(800) 669-3553

